

www.joyang.net

# HYDRAULIC GEAR PUMP

## JP 10/20/30 SERIES

We will do our best to meet customers' need through higher technology and excellent quality.



**JOYANG HYDROTECH CO., LTD.**

905-3 Woram-dong, Dalseo-gu, Daegu, Korea 704-833  
 TEL : +82-53-587-2740~1    FAX : +82-53-587-2750

**(株) 朝 陽**

본사 및 공장 : 대구광역시 달서구 월암동 905-3  
 TEL : (053)587-2740~1    FAX : (053)587-2750



**JOYANG HYDROTECH CO., LTD.**



## C O N T E N T S

Introduction to JOYANG Hydraulic Gear Pump	3
<b>JP10 SERIES</b>	
Performance Curves	4
Dimensions & Standard Specification	5
<b>JP20 SERIES</b>	
Performance Curves	6
Dimensions & Standard Specification	7
<b>JP30 SERIES</b>	
Performance Curves	8
Dimensions & Standard Specification	9
Combination Gear Pumps	10
<b>OPTION PARTS</b>	
Shaft Options	11
Mounting Flange Options	12-13
<b>How to order &amp; Port Options</b>	14
Application Information	15
How to contact	16

## SAFETY PRECAUTION

Before using any product listed in this catalog, carefully read its operating instructions

All information, illustrations and specifications in this manual are based on latest information available at the time of publication. The right is reserved to make changes at any time without notice.

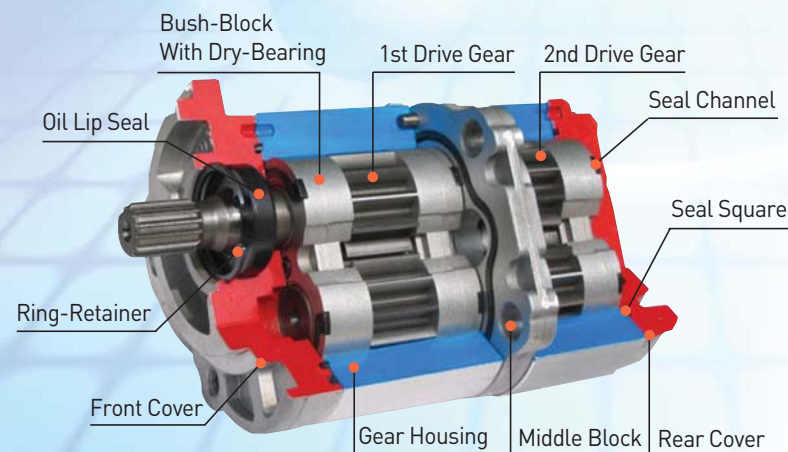

## Introduction to JOYANG Hydraulic Gear Pump

### [ FEATURE ]

- **JOYANG JP SERIES** provides the ultimate in flexibility and powerful family of hydraulic gear pumps with numerous displacements, features, and shaft/port option. The JP-series offers the design of a compact, lightweights and efficient line of pumps with pressure-balanced design for high volumetric, mechanical and overall efficiencies. They feature three-piece construction with high strength extrusion aluminum alloy body.
- **JP10 SERIES** pumps are available in twelve basic displacements from 1.2 to 10.0cc/rev, operating at continuous pressures to 210bar and speed to 3000rpm.
- **JP20 SERIES** pumps are available in fourteen basic displacements from 4.8 to 31cc/rev, operating at continuous pressures to 230bar and speed to 3000rpm.
- **JP30 SERIES** pumps are available in ten basic displacements from 21.0 to 63.0cc/rev, operating at continuous pressures to 250bar and speed to 3000rpm. Complete information can be found by referring to specific sections of this catalog.

### [ NOTICE OF USAGE ]

#### 1. Rotational Direction

The pump may rotate either clockwise C.W(R) or counter clockwise C.C.W(L), as viewed from the drive shaft.

#### 2. Filtration

Recommended filtration is 150 to 200-mesh suction filter. Further, the degree of contamination of in-tank hydraulic oil should be maintained to be NAS Class 11.

#### 3. Drive Shaft Centering Accuracy

When employing a flexible coupling, adjust the concentricity to less than 0.15 TIR, if direct-coupled, adjust the concentricity to less than 0.1 TIR between the pilot mounting diameter and the drive shaft of the pump. For gear or belt drive, please contact our Engineering Dept.

#### 4. System Plumbing

The major objective in the specification of tubing and hose sizes is to limit maximum oil velocity. To avoid pump cavitation, maximum inlet line flow should not exceed 2.4m/sec and inlet vacuum should not exceed 150mmHg(0.2kg/cm<sup>2</sup>) at the normal operating temperature.

On cold starts, a vacuum of 460mmHg(0.6kg/cm<sup>2</sup>) can be tolerated for short durations.

Pump discharge lines should have flow velocities under 6.1m/sec.

#### 5. Hydraulic Oil

The viscosity of hydraulic oil used should be ISO VG32 to VG68 or equivalent. Recommended viscosity is between 20 and 60 cSt(mm<sup>2</sup>/s). The viscosity range of 10 to 400 cSt(mm<sup>2</sup>/s) is applicable under load.

#### 6. Oil temperature

The temperature range at normal operation is 0 to 80 °C. -20 to 100 °C range is also applicable for a while

#### 7. Oil Reservoir

The reservoirs are ideally sized so the volume of reservoir oil is not replaced more than twice per minute.

# JP10 SERIES

HYDRAULIC GEAR PUMP

# JP10 SERIES

HYDRAULIC GEAR PUMP



JP10 Series pumps are available in twelve basic displacements from 1.2 to 10.0cc/rev

The JP10 series are a floating bush-block, pressure balanced design with a high strength extruded aluminum body and aluminum die-casting end cap and mounting flange.

### [ FEATURE ]

- Continuous operating pressure to 210 bar
- 12 tooth low noise and pressure ripple gear design
- Single and multiple sections pumps
- High efficiency gear profiles
- Compact and lightweight
- Low costs over the product's life

Each curve has been obtained at 50°C, using oil with viscosity 36mm<sup>2</sup>/s at 40°C and at these pressures.

### Delivery to Revolving Speed Curve

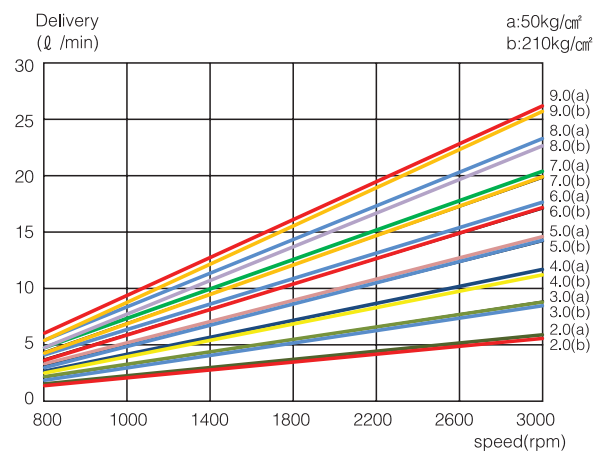

### Absorbed torque Curve

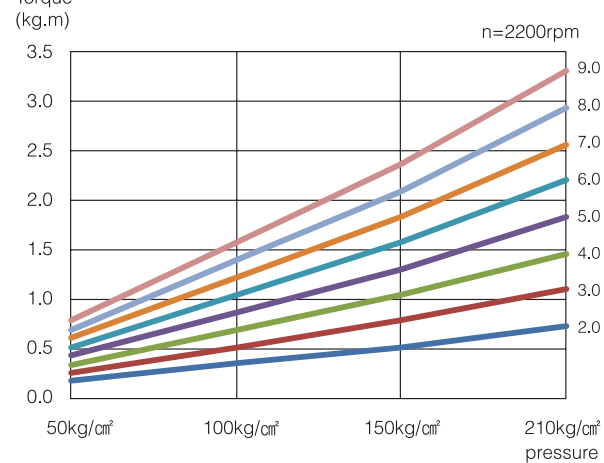

### Volumetric Curve

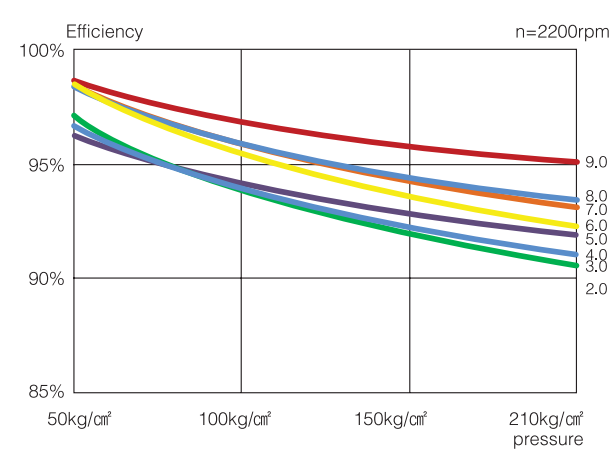

### Dimensions

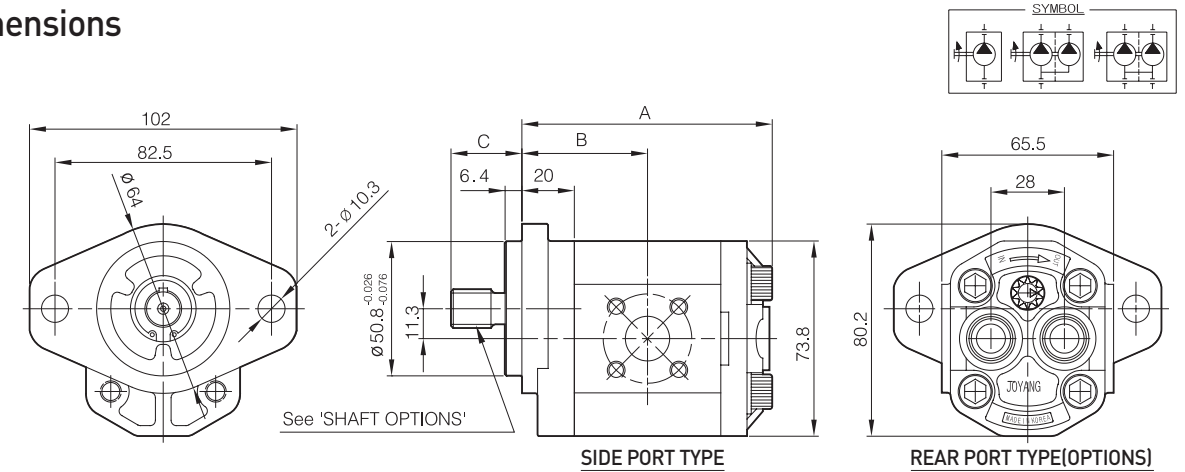

### DIMENSION TABLE

[mm]	
AA	K + 118
BB	[K/2] + 44
K = (Q1+Q2) / 0.322	
Q1 : Displacement of 1st Pump(cc/rev)	
Q2 : Displacement of 2nd Pump(cc/rev)	

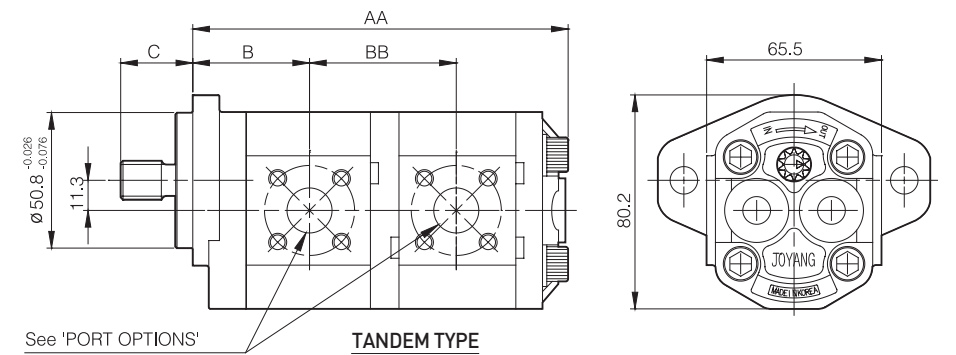

### Standard Specifications

TYPE/ DISPLACEMENT	PRESSURE (bar)		SPEED(RPM)		DIMENSIONS(mm)					THREAD PORT TYPES	
	Rated	Max	Min	Max	A	B	C	AA	BB	INLET	OUTLET
1.2	210	230	500	3000	77.2	38.9	SEE "SHAFT OPTIONS"	SEE "DIMENSION TABLE"	PF 3/8	PF 3/8	PF 3/8
2.0	210	230	500	3000	80.3	40.2					
3.0	210	230	500	3000	83.4	41.7					
3.7	210	230	500	3000	85.6	42.8					
4.0	210	230	500	3000	86.5	43.3					
4.6	210	230	500	3000	88.4	44.2					
5.0	210	230	500	3000	89.6	44.8			PF 1/2	PF 1/2	
6.0	210	230	500	3000	92.7	46.4					
7.0	190	210	500	3000	95.9	47.9					
8.0	180	200	500	3000	99.0	49.5					
9.0	170	190	500	3000	102.1	51					
10.0	170	190	500	3000	105.2	52.6					



# JP20 SERIES

HYDRAULIC GEAR PUMP

# JP20 SERIES

HYDRAULIC GEAR PUMP



JP20 Series pumps are available in fourteen basic displacements from 4.8 to 31cc/rev.

The JP20 series are a floating bush-block, pressure balanced design with a high strength extruded aluminum body and aluminum die-casting end cap and mounting flange.

### [ FEATURE ]

- Continuous operating pressure to 230bar
- 12 tooth low noise and pressure ripple gear design
- Single and multiple section pumps
- Isolated sections for applications requiring separate fluids or reservoirs
- Common and separate inlets
- Relief valve attached options

Each curve has been obtained at 50°C, using oil with viscosity 36mm<sup>2</sup>/s at 40°C and at these pressures.

### Delivery to Revolving Speed Curve

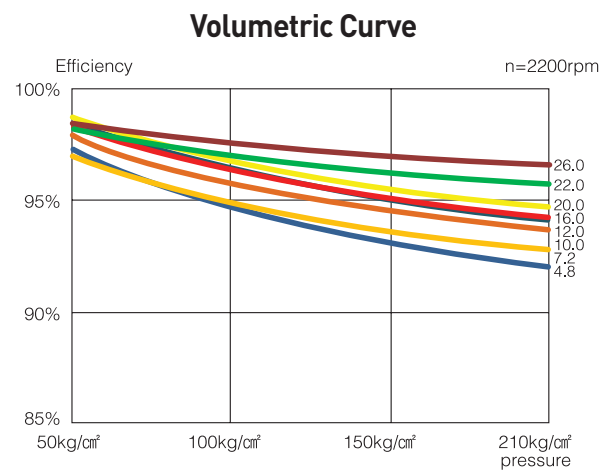
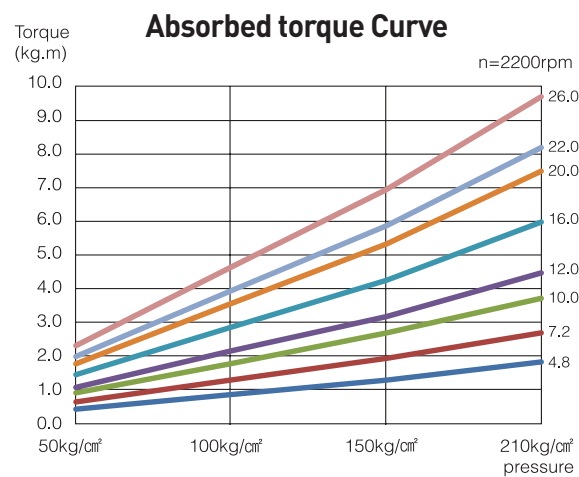
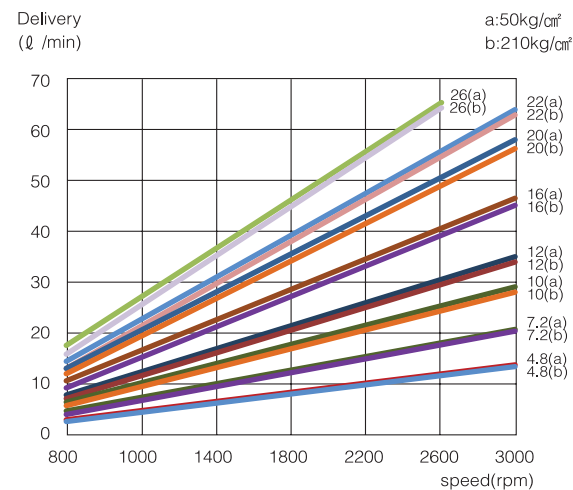

### Dimensions

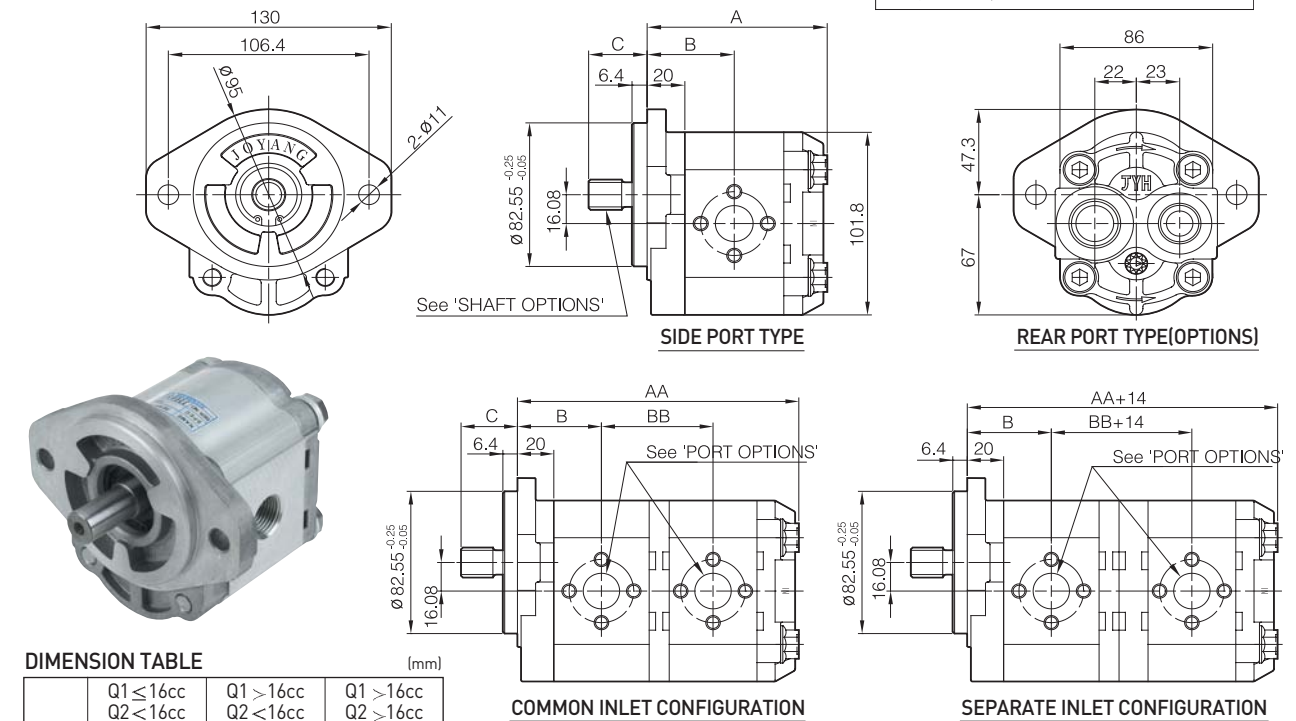

	Q1 ≤ 16cc Q2 ≤ 16cc	Q1 > 16cc Q2 ≤ 16cc	Q1 > 16cc Q2 > 16cc
AA	K + 125.3	K + 135.3	K + 145.3
BB	(K/2) + 45.3	(K/2) + 50.3	(K/2) + 55.3
K = (Q1+Q2) / 0.65			

Q1 : Displacement of 1st Pump(cc/rev)  
Q2 : Displacement of 2nd Pump(cc/rev)

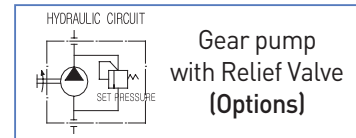

### Standard Specifications

TYPE/ DISPLACEMENT	PRESSURE (bar)		SPEED(RPM)		DIMENSIONS(mm)					THREAD PORT TYPES	
	Rated	Max	Min	Max	A	B	C	AA	BB	INLET	OUTLET
4.8	230	250	500	3000	87.0	40.7	31	SEE "DIMENSION TABLE"	PF 3/4	PF 1/2	
6.5	230	250	500	3000	89.6	42.0					
7.2	230	250	500	3000	91.9	42.6					
8.0	230	250	500	3000	93.4	43.2					
10.0	220	240	500	3000	94.9	44.7					
12.0	220	240	500	3000	98.0	46.2					
14.0	210	230	500	3000	101.0	47.8					
16.0	210	230	500	3000	104.1	49.3					
18.0	210	230	500	3000	117.2	55.8					
20.0	210	230	500	3000	120.2	57.4					
22.0	210	230	500	3000	123.3	58.9	33	PF 1	PF 3/4		
26.0	200	220	500	3000	129.9	62.0					
28.0	200	220	500	3000	135.5	63.5					
31.0	180	200	500	3000	137.0	65.8					

# JP30 SERIES

HYDRAULIC GEAR PUMP

# JP30 SERIES

HYDRAULIC GEAR PUMP



JP30 Series pumps are available in thirteen basic displacements from 14 to 63cc/rev.

The JP30 series are a floating bush-block, pressure balanced design with a high strength extruded aluminum body and cast iron end cap and mounting flange.

### [ FEATURE ]

- Continuous operating pressure to 250bar
- 12 tooth low noise and pressure ripple gear design
- Single and multiple section pumps and multiple pumps with different series
- SAE, DIN & ISO flange, shaft and porting styles

Each curve has been obtained at 50°C, using oil with viscosity 36mm<sup>2</sup>/s at 40°C and at these pressures.

### Delivery to Revolving Speed Curve

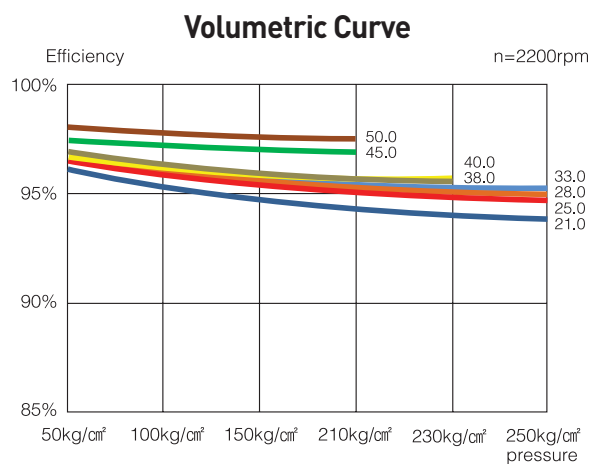
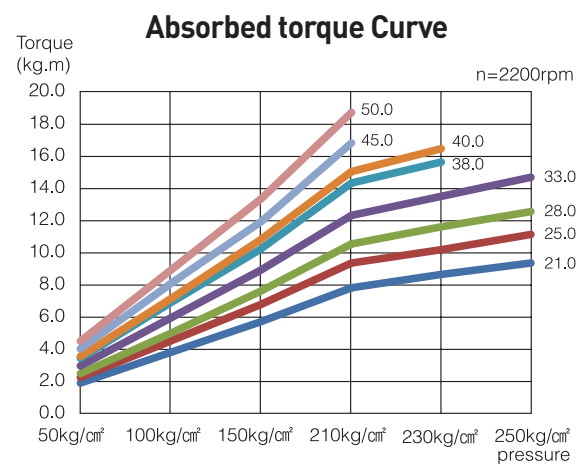
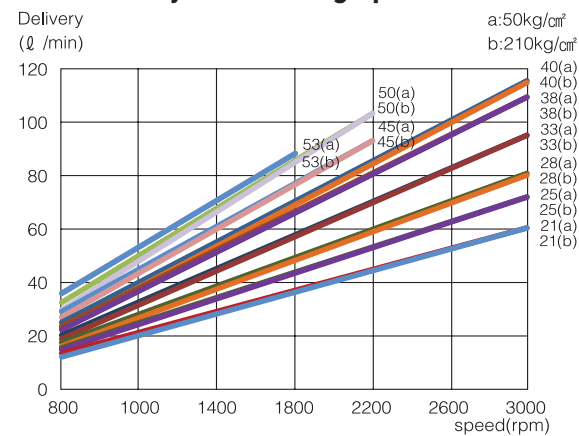

### Dimensions

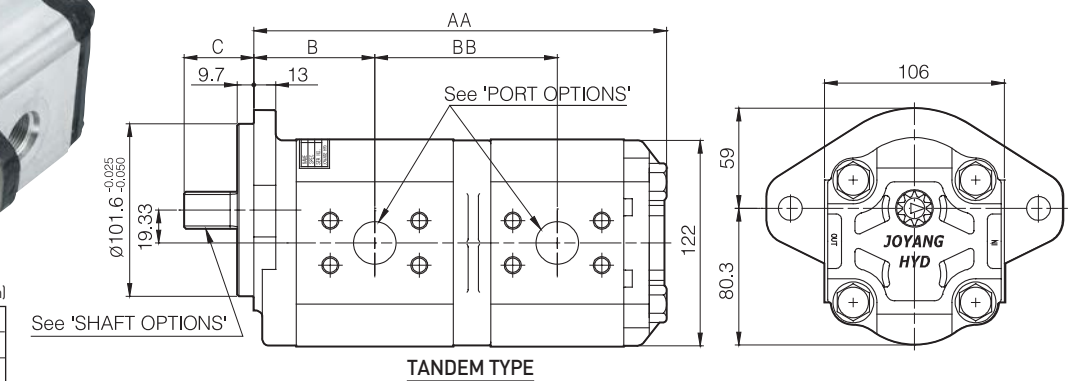
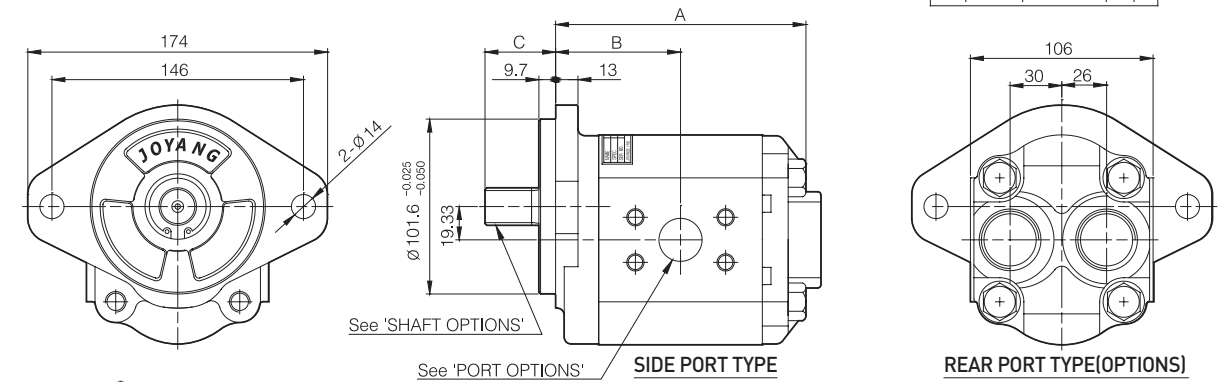

### DIMENSION TABLE (mm)

AA	K + 180.3
BB	[K/2] + 22
K = (Q1+Q2) / 0.9313	

Q1 : Displacement of 1st Pump(cc/rev)  
Q2 : Displacement of 2nd Pump(cc/rev)

### Standard Specifications

TYPE/ DISPLACEMENT	PRESSURE (bar)		SPEED(RPM)		DIMENSIONS(mm)					THREAD PORT TYPES		
	Q(CC/REV)	Rated	Max	Min	Max	A	B	C	AA	BB	INLET	OUTLET
14	250	280	500	3000	119.3	59.5	SEE "SHAFT OPTIONS"	SEE "DIMENSION TABLE"	PF 1	PF 3/4		
16	250	280	500	3000	121.5	60.6						
16	250	280	500	3000	124.7	62.2						
21	250	280	500	3000	126.8	63.3						
25	250	280	500	3000	131.1	65.4						
28	250	280	500	3000	134.4	67						
33	250	280	500	3000	139.7	69.7			PF 1/4	PF 1		
38	230	260	500	3000	145.1	72.4						
40	230	260	500	3000	147.3	73.5						
45	210	240	500	2500	152.6	76.2						
50	210	240	500	2500	158	78.8						
53	190	220	500	2000	161.2	80.5						
63	190	220	500	2000	171.9	85.8						



# JP30 SERIES

HYDRAULIC GEAR PUMP

# SHAFT OPTIONS

HYDRAULIC GEAR PUMP

## Combination Gear Pumps

### JP30 + JP10 SERIES

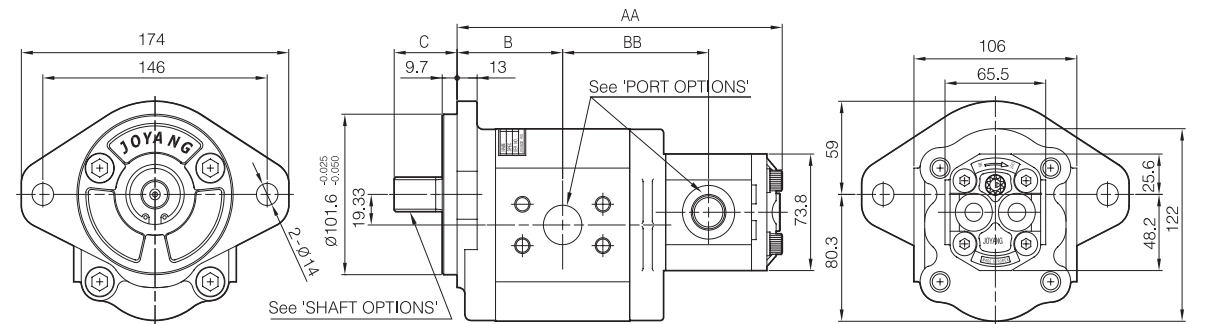

### JP30 + JP20 SERIES

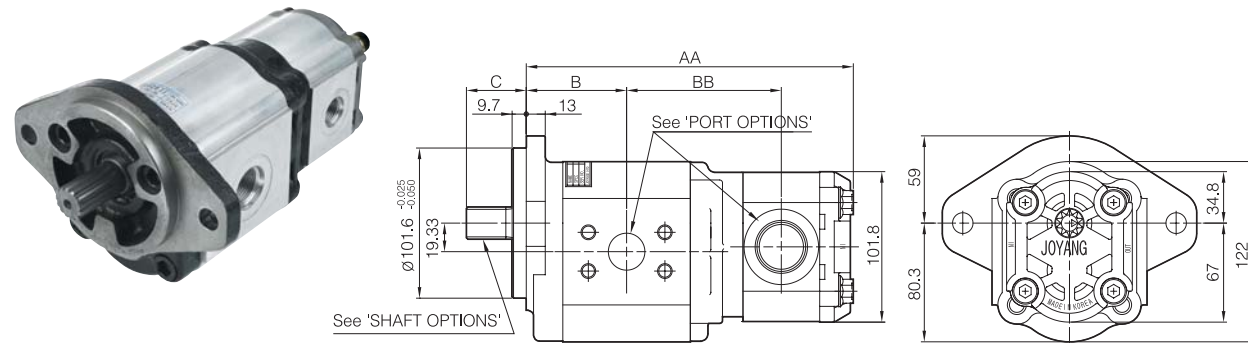

## Standard Specifications

Series	JP30/33		JP30/38		JP30/40		JP30/45		JP30/50		JP30/53	
	B	AA	BB	B	AA	BB	B	AA	BB	B	AA	BB
JP10/3	70	166	72	72	166	72	73	166	72	76	166	72
JP10/4		169	74		169	74		169	74			
JP10/6		175	77		175	77		175	77			
JP10/8		181	80		181	80		181	80			
JP20/10		190	88		190	88		190	88			
JP20/14		196	91		196	91		196	91			
JP20/16		199	92		199	92		199	92			
JP20/18		212	99		212	99		212	99			

Application Series	Code No.	Shaft End Type	Dimension			Torque Range	DRAWING
			A	B	C		
JP10	S1-1	JIS D 2001 12T Spline	13.8	17.5	26	MAX.80Nm	
	S2	SAE 'AA' Straight Key	12.7	3.2×3.2×15	27	MAX. 27Nm	
	S3	TANG TYPE	10	5	12	MAX. 35Nm	
JP20	S1-1	JIS D 2001 12T Spline	13.8	17.5	30	MAX. 80Nm	
	S1-2	JIS D 2001 15T Spline	16.8	20	30	MAX.150Nm	
	S4-1	SAE 16/32 9T Spline	15.3	17.5 (30)	31 (33)	MAX.100Nm	
	S4-2	SAE 16/32 10T Spline	16.95	17.5 (21)	31 (33)	MAX.135Nm	
	S4-3	SAE 16/32 11T Spline	18.35	18.5 (21)	31 (33)	MAX.160Nm	
	S5	DIN 5482-B17×14 9T Spline	16.5	18	31	MAX.150Nm	
	S6	SAE A Straight Key	15.88	4×4×18	32	MAX. 70Nm	
S7	Taper Shaft 1:8 Woodruff Key	16.65	3.15 × Ø16	26.5	MAX.135Nm		
JP30	S10-1	SAE 16/32 13T Spline	21.8	33.3	41.2	MAX.300Nm	
	S10-2	SAE 16/32 15T Spline	24.98	38.1	46	MAX.450Nm	
	S11	SAE B Straight Key	22.22	6.35×6.35×25.4	41.2	MAX.200Nm	
	S12	Taper Shaft 1:8 Woodruff Key	21.59	4×7.5×Ø19	32.6	MAX.240Nm	

# MOUNTING FLANGE OPTIONS

HYDRAULIC GEAR PUMP

# MOUNTING FLANGE OPTIONS

HYDRAULIC GEAR PUMP

<b>F11</b> SAE "A-A" FLANGE	<b>F12</b> 2 of 4 BOLT FIX FLANGE
<b>F13</b> JAPAN TYPE FLANGE	<b>F14</b> GERMAN TYPE FLANGE
<b>F21</b> SAE "A" FLANGE	<b>F22</b> SAE "A-A" FLANGE
<b>F23</b> 4 BOLT FLANGE #1	<b>F24</b> 4 BOLT FLANGE #2

<b>F25</b> SQUARE FLANGE	<b>F26</b> ITALIAN TYPE FLANGE
<b>F27</b> GERMAN TYPE FLANGE	<b>F28</b> PERKINS 1000 FLANGE
<b>F31</b> SAE "A" FLANGE	<b>F32</b> SAE "B" FLANGE
<b>F33</b> RECTANGULAR FLANGE	

### Ordering Code Example

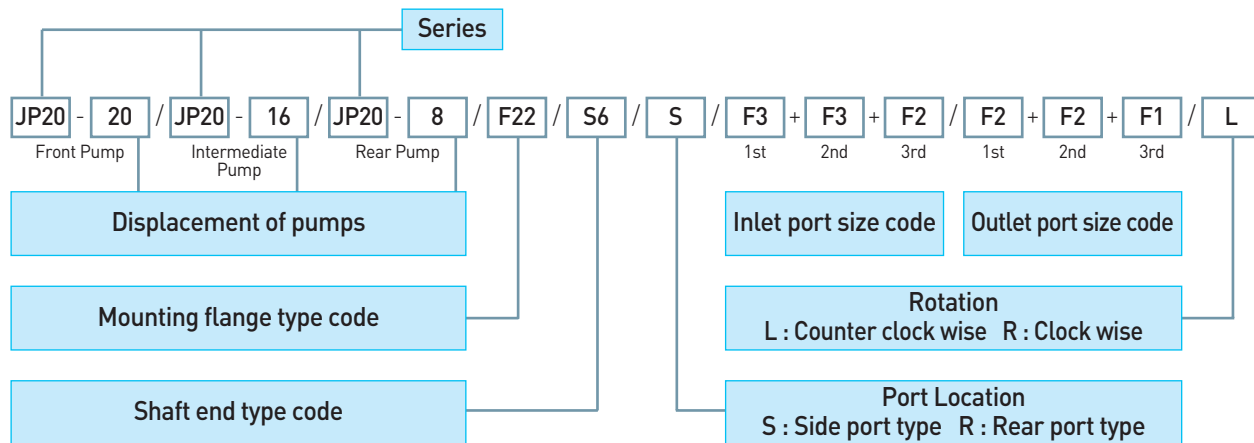

### PORT OPTIONS

#### THREAD PORT IN/OUT SIZE

TYPE	PF THREAD TYPE					UNF THREAD TYPE					
	CODE	F1(f1)	F2(f2)	F3(f3)	F4(f4)	F5(f5)	U1(u1)	U2(u2)	U3(u3)	U4(u4)	U5(u5)
SIZE		3/8"	1/2"	3/4"	1"	1-1/4"	9/16-18	7/8-14	1-1/16-12	1-5/16-12	1-5/8-12

\*Capital Letter:  
O-Ring Boss Type **ex)**

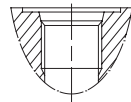

\*Small Letter:  
Copper Packing Type **ex)**

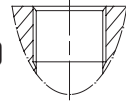

#### FLANGE PORT IN/OUT SIZE

TYPE	SAE Split Ports			4 Bolts Flange						
	CODE	G1	G2	G3	H1	H2	H3	H4	h1	h2
Nominal Size		3/4	1	1-1/4	16	20	24	27	16	20
Dim (mm)	A	20	24	31	16	20	24	27	16	20
	B	47.63	52.37	58.72	35.6	40	55	55	35.6	40
	C	22.23	26.19	30.17	-	-	-	-	-	-
	D	M10×14dp			M6×12dp	M8×14dp		M10×14dp	M6×12dp	M8×14dp

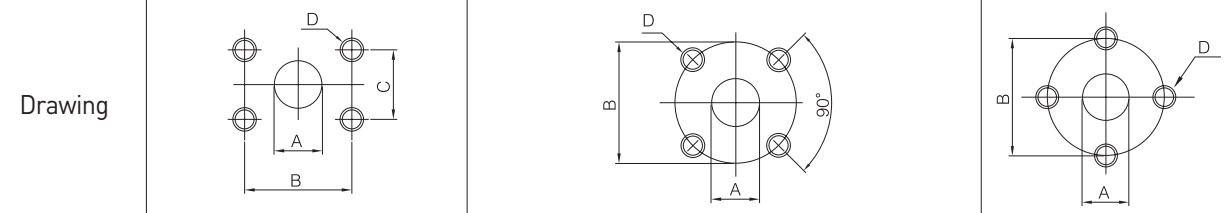

### Design calculations for pumps

The design calculations for pumps are based on the following parameters:

Vc [cm <sup>3</sup> /rev]	Pump displacement
n [r/min]	Drive speed
Q [l/min]	Flow rate
P [kgf/cm <sup>2</sup> ]	Operating pressure
T <sub>theo</sub> [kgf.m]	Theoretical torque
T <sub>act</sub> [kgf.m]	Actual torque
H [PS]	Horsepower
N [Kw]	Power
η <sub>v</sub> [%]	Volumetric efficiency
η <sub>m</sub> [%]	Mechanical efficiency
η <sub>t</sub> [%]	Total efficiency

The following formulas describe the various relationships.

They include correction factors for adapting the parameters to the usual units encountered in practice.

#### [ Convension Unit ]

1 kgf/cm <sup>2</sup>	0.9807bar
1 kgf-m	9.807N · m
1 Kw	1.36PS

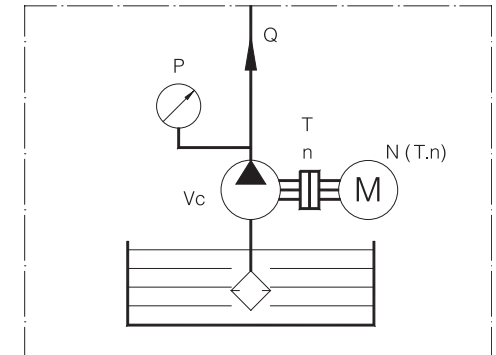

$$Q = \frac{Vc \cdot n}{100000} \cdot \eta_v$$

$$Vc = \frac{100000 \cdot Q}{n \cdot \eta_v} \quad n = \frac{100000 \cdot Q}{Vc \cdot \eta_v}$$

$$N = \frac{Q \cdot P}{612 \cdot \eta_t} \quad P = \frac{N \cdot 612 \cdot \eta_t}{Q}$$

$$T_{theo} = 716.2 \cdot \frac{H}{n} \quad T_{theo} = 974 \cdot \frac{N}{n}$$

$$T_{theo} = \frac{P \cdot Vc}{200\pi} \quad \eta_t = \eta_v \cdot \eta_m$$

$$\eta_v = \frac{Q_{act}}{Q_{theo}} \times 100 \quad \eta_m = \frac{T_{theo}}{T_{act}} \times 100$$

### Installation and commissioning

- Fill the pump with fluid before installing.
- Check the direction of rotation.
- Before installing the pump, clean the pipes thoroughly of all dirt, scale, sand, swarf, etc. Welded pipes in particular must be pickled or flushed out.
- Before starting up the pump for the first time, the entire hydraulic system must be thoroughly purged of air.
- Cover the shaft seal when spraying or brush-painting the equipment.
- Pay close attention to the specification, especially speeds, pressures and suction vacuum.

### Accuracy of pump mounting section

- when directly driven  
(Torque converter PTO, Engine PTO, etc)  
Radial runout TIR between drive shaft and pump mounting pilot bore : 0.1mm max.
- when using flexible coupling  
The radial runout and face runout must be within the allowance of the coupling used and the coupling must be selected to confirm to the pump input horsepower. Do not let the radial load and thrust load be applied to the pump shaft. Do not strike the coupling when assembling/disassembling